



15NM60-U2

Preliminary

Power MOSFET

**15A, 600V N-CHANNEL
SUPER-JUNCTION MOSFET**

■ DESCRIPTION

The **UTC 15NM60-U2** is a Super Junction MOSFET Structure and is designed to have better characteristics, such as fast switching time, low gate charge, low on-state resistance and a high rugged avalanche characteristics. This power MOSFET is usually used at DC-DC, AC-DC converters for power applications.

■ FEATURES

- * $R_{DS(ON)} < 0.38\Omega @ V_{GS}=10V, I_D=7.5A$
- * By using Super Junction Structure
- * Fast Switching
- * With 100% Avalanche Tested

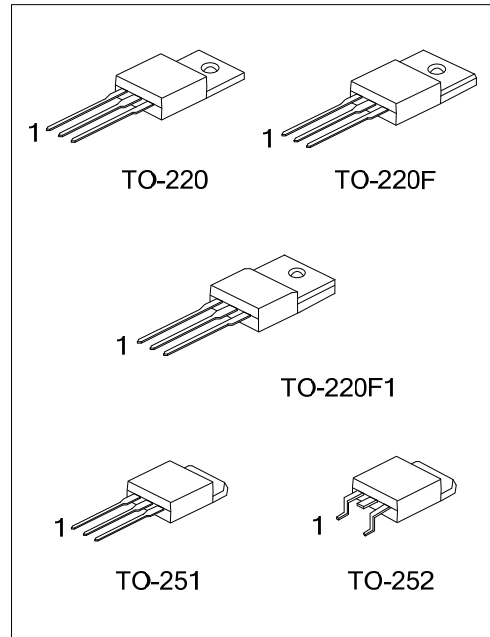

■ SYMBOL

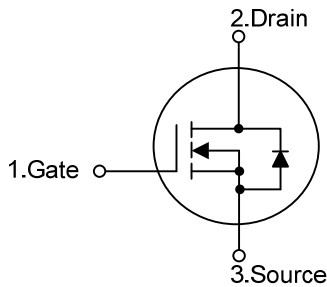

■ ORDERING INFORMATION

Ordering Number		Package	Pin Assignment			Packing
Lead Free	Halogen Free		1	2	3	
15NM60L-TA3-T	15NM60G-TA3-T	TO-220	G	D	S	Tube
15NM60L-TF3-T	15NM60G-TF3-T	TO-220F	G	D	S	Tube
15NM60L-TF1-T	15NM60G-TF1-T	TO-220F1	G	D	S	Tube
15NM60L-TM3-T	15NM60G-TM3-T	TO-251	G	D	S	Tube
15NM60L-TN3-R	15NM60G-TN3-R	TO-252	G	D	S	Tape Reel

Note: Pin Assignment: G: Gate D: Drain S: Source

<p>15NM60L-TF1-T</p> <p>(1)Packing Type</p> <p>(2)Package Type</p> <p>(3)Green Package</p>	<p>(1) T: Tube, R: Tape Reel</p> <p>(2) TA3: TO-220, TF3: TO-220F, TF1: TO-220F1, TM3: TO-251, TN3: TO-252</p> <p>(3) L: Lead Free, G: Halogen Free and Lead Free</p>
--	---

■ MARKING

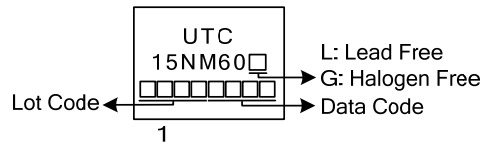

■ ABSOLUTE MAXIMUM RATINGS ($T_C=25^\circ\text{C}$, unless otherwise specified)

PARAMETER		SYMBOL	RATINGS	UNIT
Drain-Source Voltage		V_{DSS}	600	V
Gate-Source Voltage		V_{GSS}	± 30	V
Continuous Drain Current	Continuous	I_D	15	A
Pulsed Drain Current	Pulsed (Note 2)	I_{DM}	60	A
Avalanche Current (Note 3)		I_{AR}	3.1	A
Avalanche energy	Single Pulsed (Note 3)	E_{AS}	490	mJ
Peak Diode Recovery dv/dt (Note 4)		dv/dt	7.5	V/nS
Power Dissipation	TO-220	P_D	250	W
	TO-220F/TO-220F1		38.5	W
	TO-251/TO-252		85	W
Junction Temperature		T_J	+150	$^\circ\text{C}$
Storage Temperature Range		T_{STG}	-55 ~ +150	$^\circ\text{C}$

Notes: 1. Absolute maximum ratings are those values beyond which the device could be permanently damaged.

Absolute maximum ratings are stress ratings only and functional device operation is not implied.

2. Repetitive Rating: Pulse width limited by maximum junction temperature.

3. $L=102\text{mH}$, $I_{AS}=3.1\text{A}$, $V_{DD}=50\text{V}$, $R_G=25\Omega$, Starting $T_J = 25^\circ\text{C}$.

4. $I_{SD} \leq 15\text{A}$, $di/dt \leq 200\text{A}/\mu\text{s}$, $V_{DD} \leq V_{(BR)DSS}$, $T_J = 25^\circ\text{C}$.

■ THERMAL DATA

PARAMETER		SYMBOL	RATINGS	UNIT
Junction to Ambient	TO-220/TO-220F	θ_{JA}	62.5	$^\circ\text{C}/\text{W}$
	TO-220F1			
	TO-251/TO-252		110	$^\circ\text{C}/\text{W}$
Junction to Case	TO-220	θ_{JC}	0.5	$^\circ\text{C}/\text{W}$
	TO-220F/TO-220F1		3.25	$^\circ\text{C}/\text{W}$
	TO-251/TO-252		1.47	$^\circ\text{C}/\text{W}$

■ ELECTRICAL CHARACTERISTICS (T_J =25°C, unless otherwise specified)

PARAMETER		SYMBOL	TEST CONDITIONS	MIN	TYP	MAX	UNIT	
OFF CHARACTERISTICS								
Drain-Source Breakdown Voltage		BV _{DSS}	V _{GS} =0V, I _D =250μA	600			V	
Drain-Source Leakage Current		I _{DSS}	V _{DS} =600V, V _{GS} =0V			10	μA	
Gate-Source Leakage Current	Forward	I _{GSS}	V _{DS} =0V, V _{GS} =+30V			+100	nA	
	Reverse		V _{DS} =0V, V _{GS} =-30V			-100	nA	
ON CHARACTERISTICS								
Gate Threshold Voltage		V _{GS(TH)}	V _{DS} = V _{GS} , I _D =250μA	2.5		4.5	V	
Drain-Source On-State Resistance		R _{DS(ON)}	V _{GS} =10V, I _D =7.5A			0.38	Ω	
DYNAMIC PARAMETERS								
Input Capacitance		C _{ISS}	V _{GS} =0V, V _{DS} =25V, f=1.0MHz		894		pF	
Output Capacitance		C _{OSS}				535		pF
Reverse Transfer Capacitance		C _{RSS}				25.5		pF
SWITCHING PARAMETERS								
Total Gate Charge (Note 1)		Q _G	V _{DS} =50V, V _{GS} =10V, I _D =1.3A, I _G =100μA (Note 1, 2)		95		nC	
Gate to Source Charge		Q _{GS}				7.3		nC
Gate to Drain Charge		Q _{GD}				28		nC
Turn-on Delay Time (Note 1)		t _{D(ON)}	V _{DD} =30V, V _{GS} =10V, I _D =0.5A, R _G =25Ω (Note 1, 2)		64		ns	
Rise Time		t _R				125		ns
Turn-off Delay Time		t _{D(OFF)}				238		ns
Fall-Time		t _F				134		ns
SOURCE- DRAIN DIODE RATINGS AND CHARACTERISTICS								
Maximum Body-Diode Pulsed Current		I _S				15	A	
Drain-Source Diode Forward Voltage (Note 1)		I _{SM}				60	A	
Maximum Body-Diode Continuous Current		V _{SD}	I _S =15A, V _{GS} =0V			1.4	V	
Reverse Recovery Time (Note 1)		t _{rr}	I _S =15A, V _{GS} =0V, dI _F /dt=100A/μs		385		ns	
Reverse Recovery Charge		Q _{rr}				5.79		μC

Note: 1. Pulse Test : Pulse width ≤ 300μs, Duty cycle ≤ 2%

2. Essentially independent of operating temperature

■ TEST CIRCUITS AND WAVEFORMS

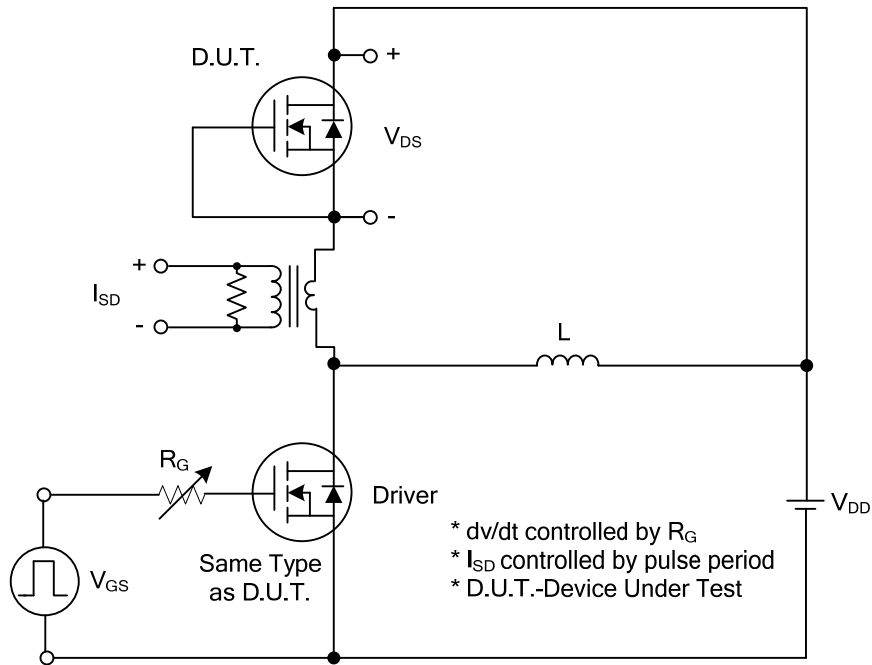

Peak Diode Recovery dv/dt Test Circuit

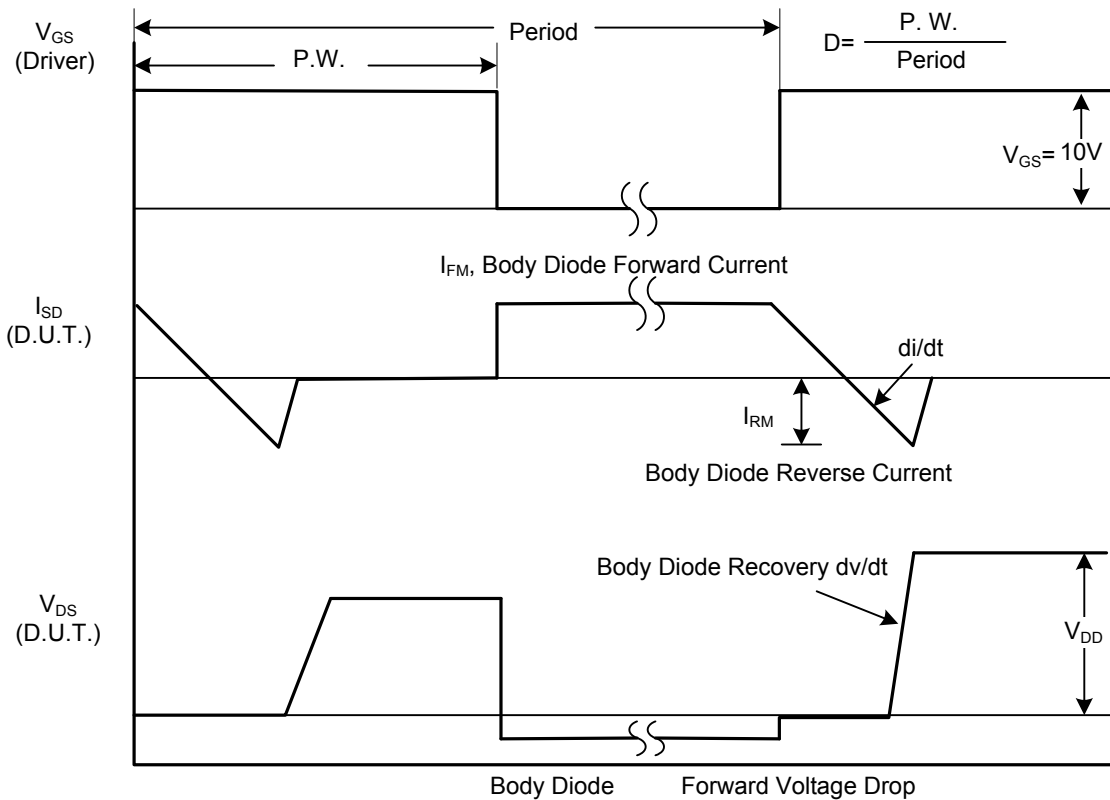

Peak Diode Recovery dv/dt Waveforms

■ TEST CIRCUITS AND WAVEFORMS (Cont.)

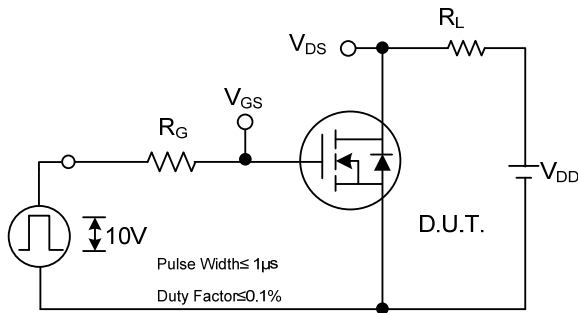

Switching Test Circuit

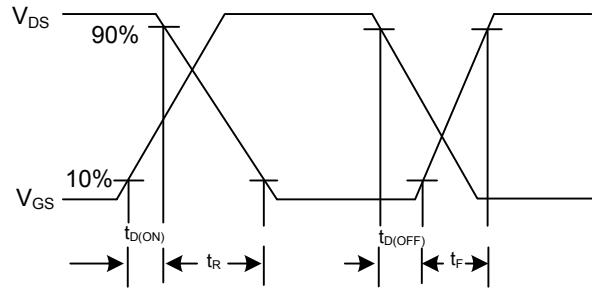

Switching Waveforms

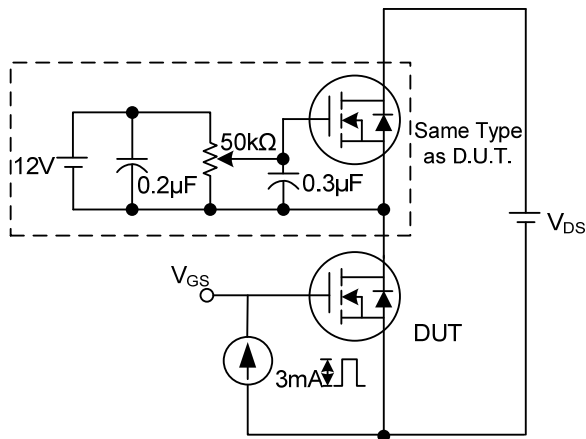

Gate Charge Test Circuit

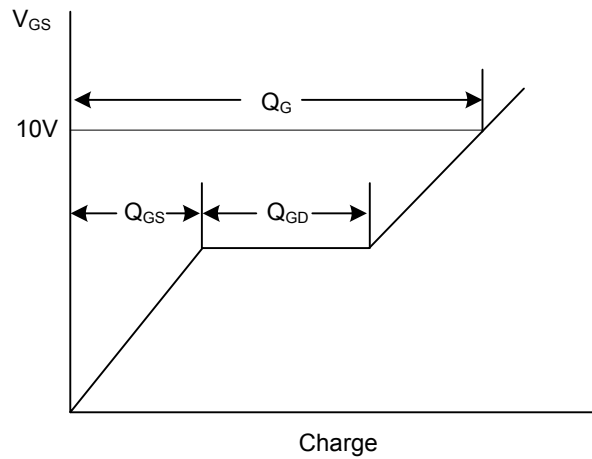

Gate Charge Waveform

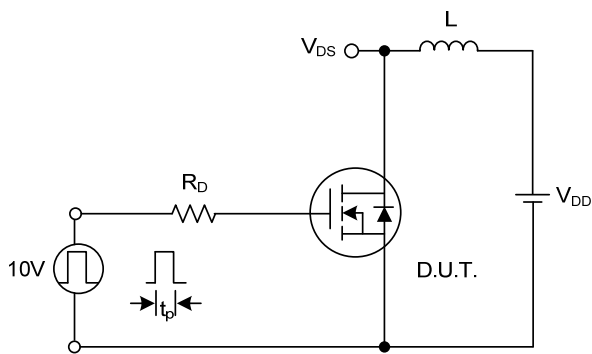

Unclamped Inductive Switching Test Circuit

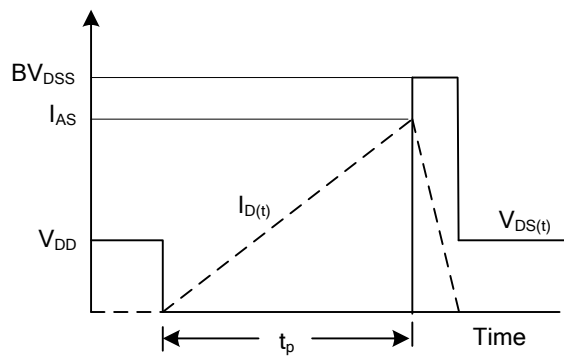

Unclamped Inductive Switching Waveforms

UTC assumes no responsibility for equipment failures that result from using products at values that exceed, even momentarily, rated values (such as maximum ratings, operating condition ranges, or other parameters) listed in products specifications of any and all UTC products described or contained herein. UTC products are not designed for use in life support appliances, devices or systems where malfunction of these products can be reasonably expected to result in personal injury. Reproduction in whole or in part is prohibited without the prior written consent of the copyright owner. The information presented in this document does not form part of any quotation or contract, is believed to be accurate and reliable and may be changed without notice.